

Hochgradienten Magnetscheider HGS

High Gradient Magnetic separator HGS

Séparateur magnétique à gradient élevé HGS

STEINERT Elektromagnetbau GmbH • Widdersdorfer Str. 329-331, D-50933 Köln • Tel.+49 (0) 221 49 84 0 • Fax +49 (0) 221 49 84 102 • sales@steinert.de

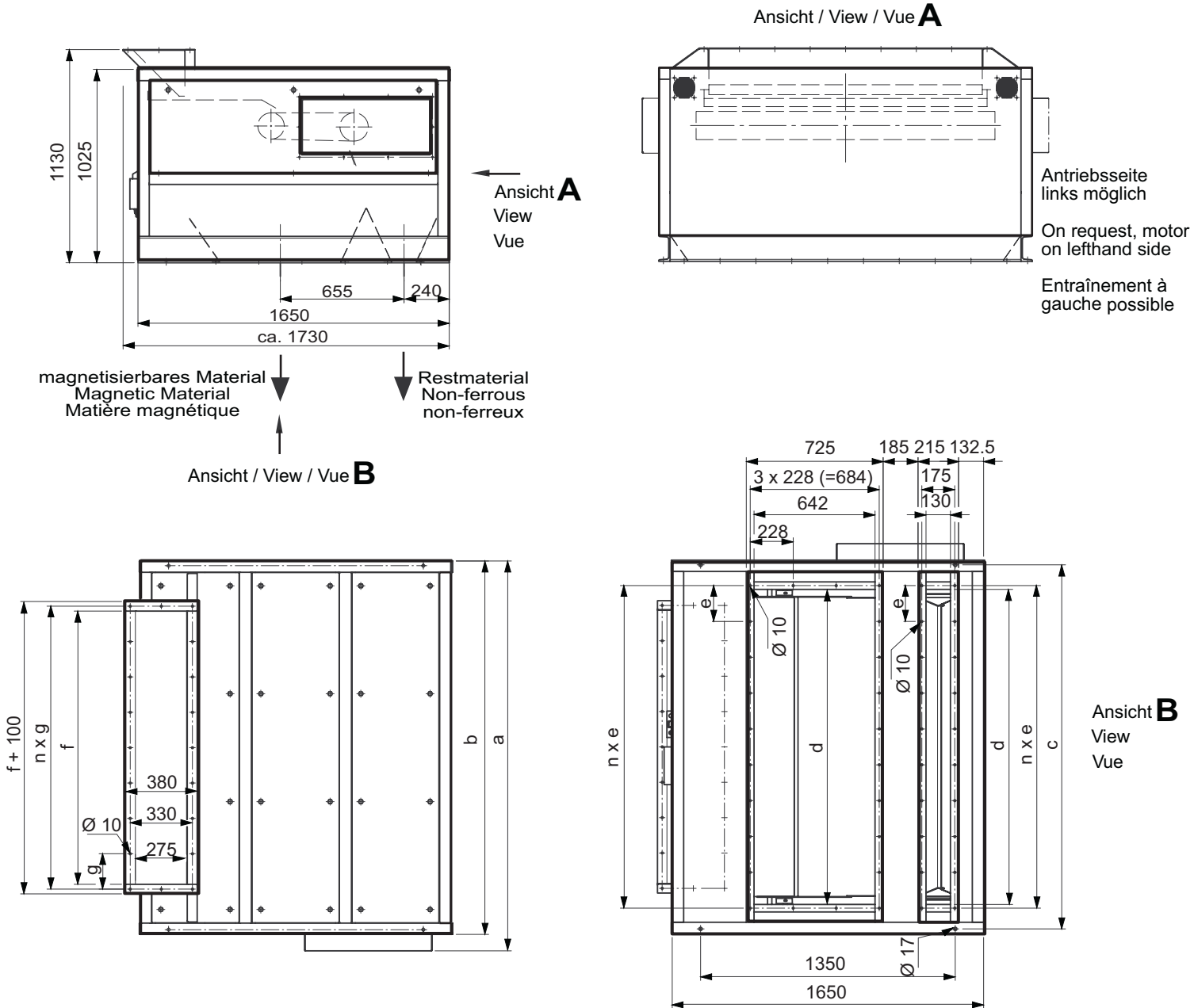

Typ Type Type	Abmessungen Dimensions Dimensions							Antrieb Drive Entraînement	Gewicht Weight Poids
	a	b	c	d	n x e	f	n x g		
	mm	mm	mm	mm	mm	mm	mm	kW	kg
HGS 50 40 S15 1	1067	980	930	670	4x177.5 (=710)	450	4x125 (=500)		690
HGS 100 40 S15 1	1567	1480	1430	1170	7x173 (=1211)	950	5x200 (=1000)	0.37	925
HGS 150 40 S15 1	2067	1980	1930	1670	9x190 (=1710)	1450	8x187.5 (=1500)		1160

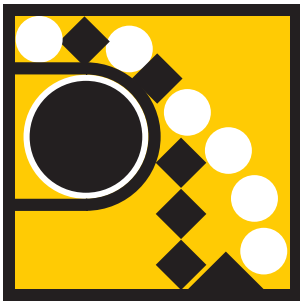

Hochgradienten Magnetscheider HGS

High Gradient Magnetic separator HGS

Séparateur magnétique à gradient élevé HGS

STEINERT Elektromagnetbau GmbH • Widdersdorfer Str. 329-331, D-50933 Köln • Tel.+49 (0) 221 49 84 0 • Fax +49 (0) 221 49 84 102 • sales@steinert.de

Ansicht / View / Vue **A**

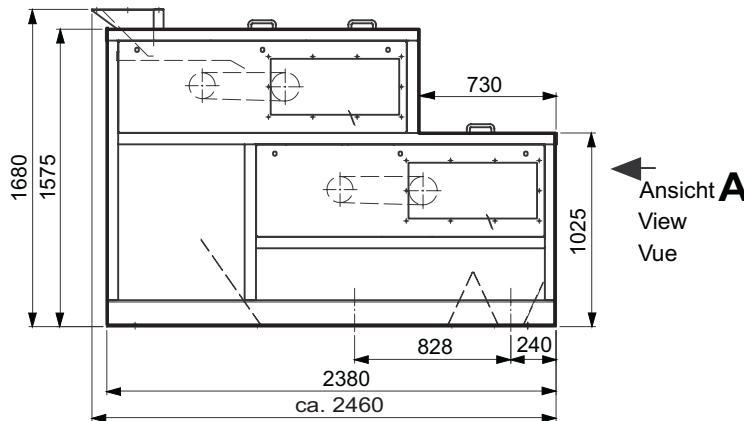

Ansicht **A**
View
Vue

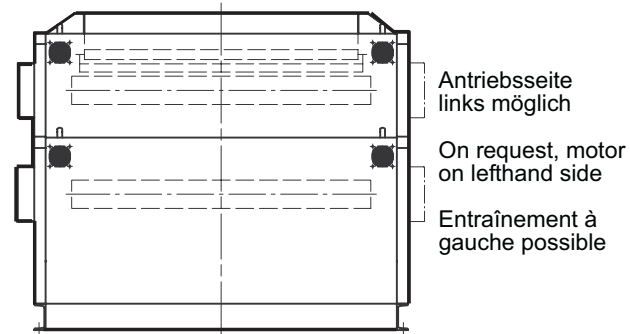

magnetisierbares Material
Magnetic Material
Matière magnétique

Restmaterial
Non-ferrous
non-ferreux

Ansicht / View / Vue **B**

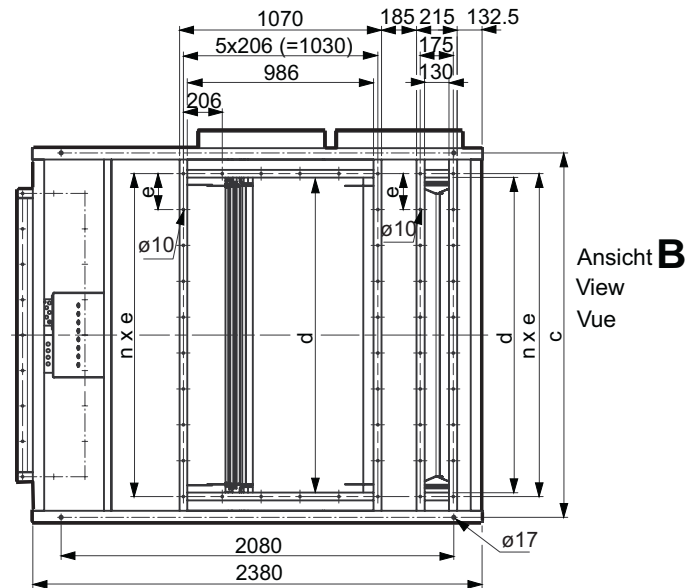
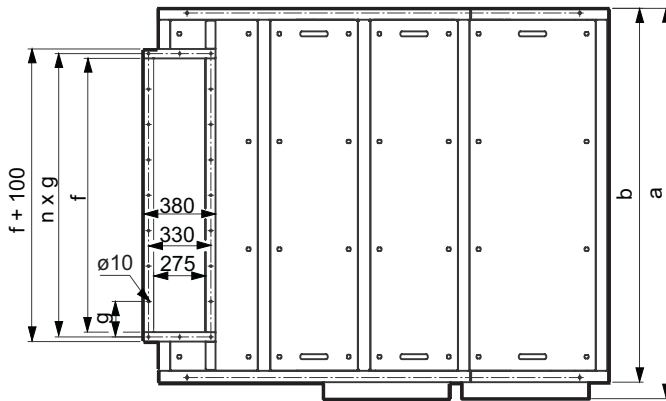

Ansicht **B**
View
Vue

Typ Type Type	Abmessungen Dimensions Dimensions							Antrieb Drive Entraînement	Gewicht Weight Poids
	a	b	c	d	n x e	f	n x g		
	mm	mm	mm	mm	mm	mm	mm	kW	kg
HGS 50 40 S15 2	1067	980	930	670	4 x 177.5 (=710)	450	4 x 125 (=500)		1000
HGS 100 40 S15 2	1567	1480	1430	1170	7 x 173 (=1211)	950	5 x 200 (=1000)	2 x 0,37	1320
HGS 150 40 S15 2	2067	1980	1930	1670	9 x 190 (=1710)	1450	8 x 187.5 (=1500)		1640